



**casagrande**

**KRC**

DIAPHRAGM WALL EQUIPMENT

ATTREZZATURE PER DIAFRAMMI





### **Kelly KRC, diaphragm wall equipment**

Casagrande started manufacturing equipment for diaphragm walls in 1963. Over the years it has developed a complete range of machines in order to satisfy all the contractor's requirements. Requests for a special machine to excavate efficiently in medium hard to soft soils led to the development of the Kelly KRC2 HD and grab type K combination. This equipment guarantees superior productivity and makes control or verticality easy in the excavation of diaphragm wall panels and barrettes. The KRC2 HD Kelly offer the following advantages:

- to get into tight corners a turntable enables the Kelly and the grab to be rotated through 45° or 180°;
- a service Jib can be fitted to the Kelly;
- easy transportation without dismounting;
- quick assembly without service crane.

### **Attrezzature per diaframmi Kelly KRC**

È dal 1963 che la Casagrande costruisce macchine per diaframmi: in questi anni ha sviluppato una gamma completa di attrezzature, tutte in grado di dare risposta a tutte le esigenze operative dei cantieri. Le esperienze specifiche maturate nei lavori su terreni di bassa e media consistenza, hanno portato allo sviluppo di un'attrezzatura particolare, composta dal Kelly KRC2 HD e dalla benna idraulica K. È un'attrezzatura che garantisce un alto livello di produttività e facilita il controllo della verticalità di scavo. Alcune caratteristiche di particolare rilevanza sono:

- ralla che consente la rotazione di 45° o 180°, particolarmente apprezzata negli spazi ristretti e negli angoli;
- possibilità di attrezzare il Kelly con un falchetto di servizio;
- facilità di trasporto senza smontaggio;
- montaggio veloce senza gru di servizio.



casagrande

**B125** XP



M318

# KRC 1 on B125XP

KRC 1 su B125XP

HYDRAULIC GRAB BENNA IDRAULICA		K2200	K2500
<b>A</b>	Height with closed jaws Altezza da terra a valve chiuse	2440	1940

KRC 1		P	P
<b>C</b>	Extension / Prolunga	(m)	(m)
	—	23	23,5
	5000	28	28,5
	6500	29,5	30

Weight of kelly bars / Peso aste ~4000 kg

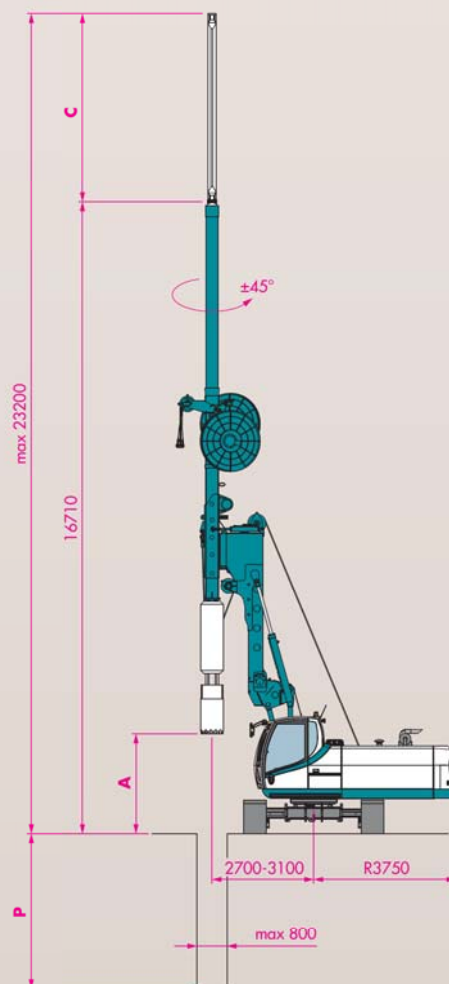

## TRANSPORT DIMENSIONS

DIMENSIONI DI TRASPORTO

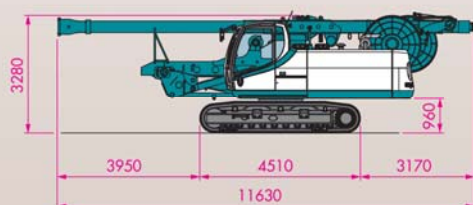

Weight / Peso ~ 35,6 t

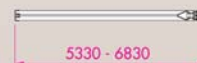

Weight / Peso ~ 500/600 kg

# KRC 1 on B175XP

KRC 1 su B175XP

HYDRAULIC GRAB BENNA IDRAULICA		K2200	K2500
<b>A</b>	Height with closed jaws Altezza da terra a valve chiuse	2460	1960

KRC 1		P	P
<b>C</b>	Extension / Prolunga	(m)	(m)
	—	23	23,5
	5000	28	28,5
	6500	29,5	30

Weight of kelly bars / Peso aste ~4000 kg

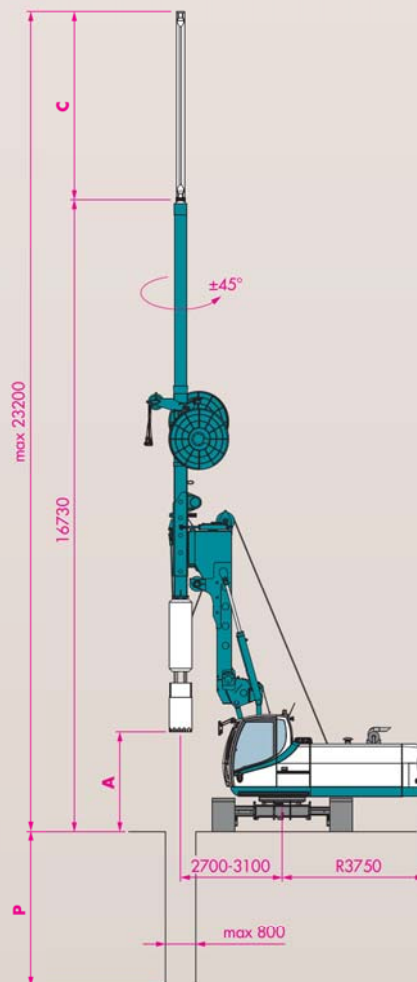

## TRANSPORT DIMENSIONS

DIMENSIONI DI TRASPORTO

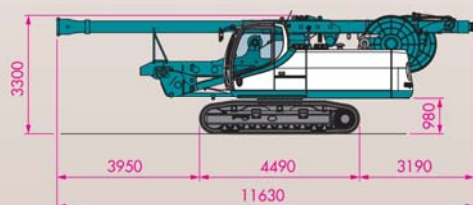

Weight / Peso ~ 36,5 t

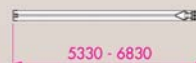

Weight / Peso ~ 500/600 kg

# KRC 2 on B200XP

KRC 2 su B200XP

HYDRAULIC GRAB BENNA IDRAULICA		K2200	K2500HD	K3000
<b>A</b>	Height with closed jaws Altezza da terra a valve chiuse	2460	1960	1460
	Spacer 1000 Distanziale 1000			
<b>B</b>	Height with closed jaws Altezza da terra a valve chiuse	1460	960	460

KRC 2-28	C	P	P	P
	Extension / Prolunga	(m)	(m)	(m)
	—	27,8	28	28,6
	2000	29,8	30	30,6
	5000	32,8	33	33,6
	7000	34,8	35	35,6
	9000	36,8	37	37,6
Weight of kelly bars / Peso aste ~6200 kg				

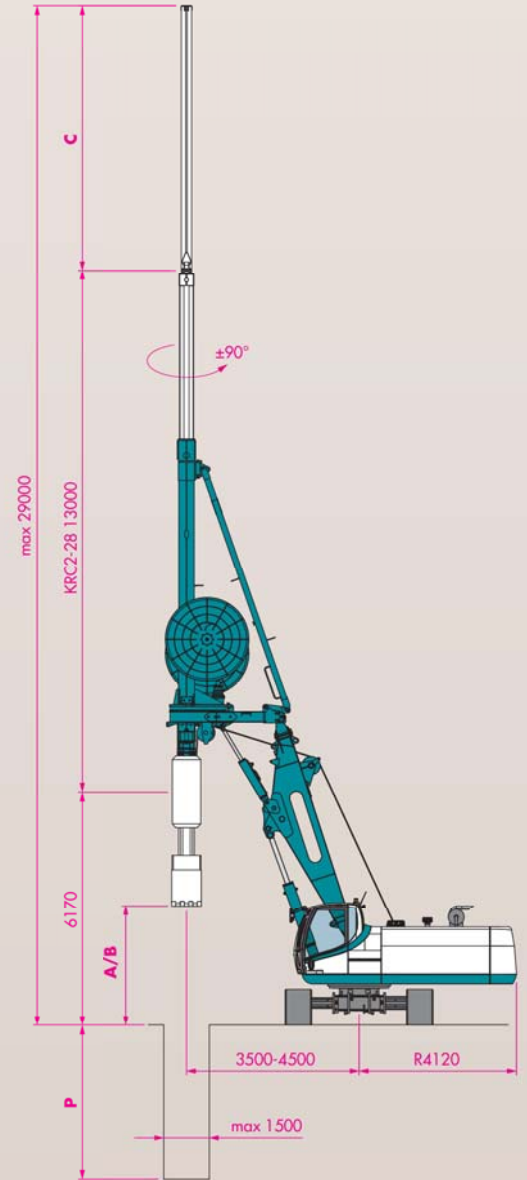

## TRANSPORT DIMENSIONS

DIMENSIONI DI TRASPORTO

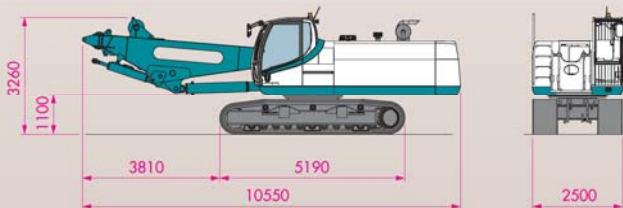

Weight / Peso ~ 46 t

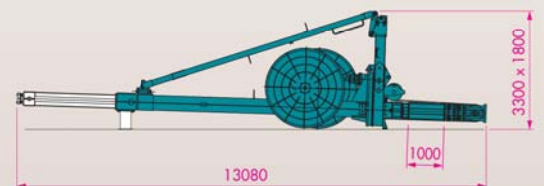

Weight / Peso ~ 13 t

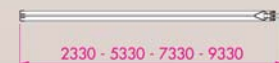

Weight / Peso ~ 300/600/770/960 kg

# KRC 2 HD on B250xp

KRC 2 HD su B250xp

HYDRAULIC GRAB BENNA IDRAULICA		K2200HD	K2500HD	K3000HD
<b>A</b>	Height with closed jaws Altezza da terra a valve chiuse	3250	3000	2330
	Spacer 1000 Distanziale 1000			
<b>B</b>	Height with closed jaws Altezza da terra a valve chiuse	2250	2000	1330

<b>KRC 2-28 HD</b>	<b>C</b>	<b>P</b>	<b>P</b>	<b>P</b>
	Extension / Prolunga	(m)	(m)	(m)
	—	27,8	28	28,5
	2000	29,8	30	30,5
	5000	32,8	33	33,5
7000	34,8	35	35,5	

Weight of kelly bars / Peso aste ~7100 kg

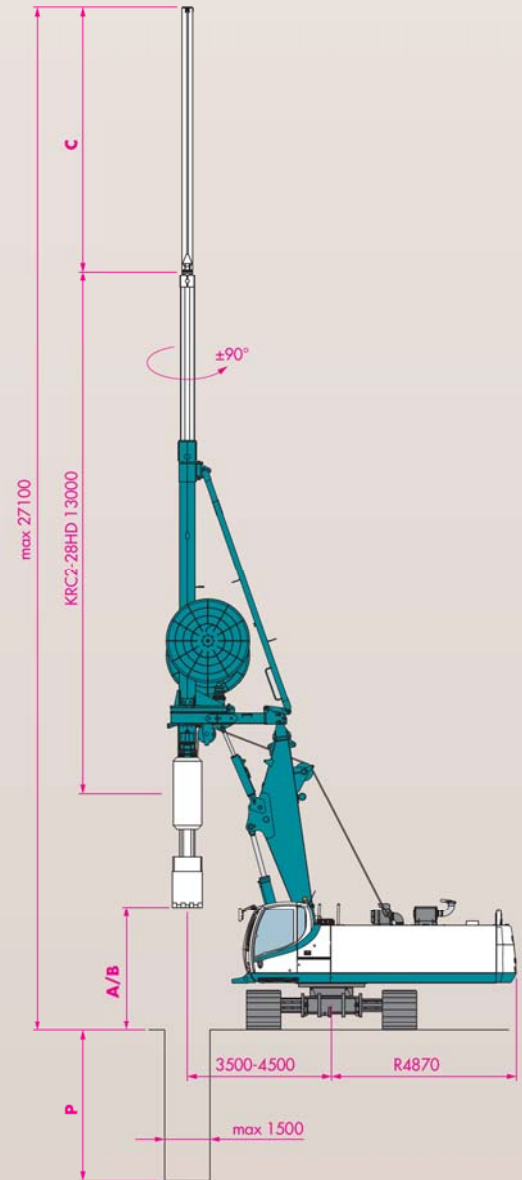

## TRANSPORT DIMENSIONS

DIMENSIONI DI TRASPORTO

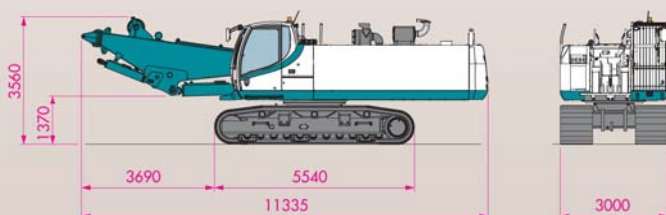

Weight / Peso ~ 54 t

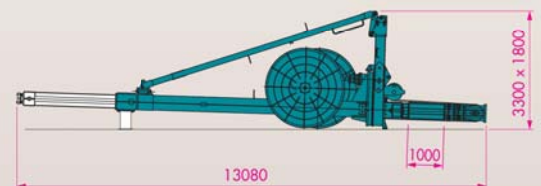

Weight / Peso ~ 14,3 t

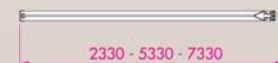

Weight / Peso ~ 300/600/770 kg

# KRC 2 HD on B300xp

KRC 2 HD su B300xp

HYDRAULIC GRAB BENNA IDRAULICA		K2200HD	K2500HD	K3000HD
<b>A</b>	Height with closed jaws Altezza da terra a valve chiuse	3280	3030	2360
	Spacer 1000 Distanziale 1000			
<b>B</b>	Height with closed jaws Altezza da terra a valve chiuse	2280	2030	1360

<b>KRC 2-28 HD</b>	<b>C</b>	<b>P</b>	<b>P</b>	<b>P</b>
	Extension / Prolunga	(m)	(m)	(m)
	—	27,8	28	28,6
	2000	29,8	30	30,6
	5000	32,8	33	33,6
	7000	34,8	35	35,6
	12000	39,8	40	40,6

Weight of kelly bars / Peso aste ~7100 kg

<b>KRC 2-33 HD</b>	<b>C</b>	<b>P</b>	<b>P</b>	<b>P</b>
	Extension / Prolunga	(m)	(m)	(m)
	—	32	33,4	34
	2000	35	35,4	36
	5000	38	38,4	39
	7000	40	40,4	41
	12000	45	45,4	46

Weight of kelly bars / Peso aste ~8200 kg

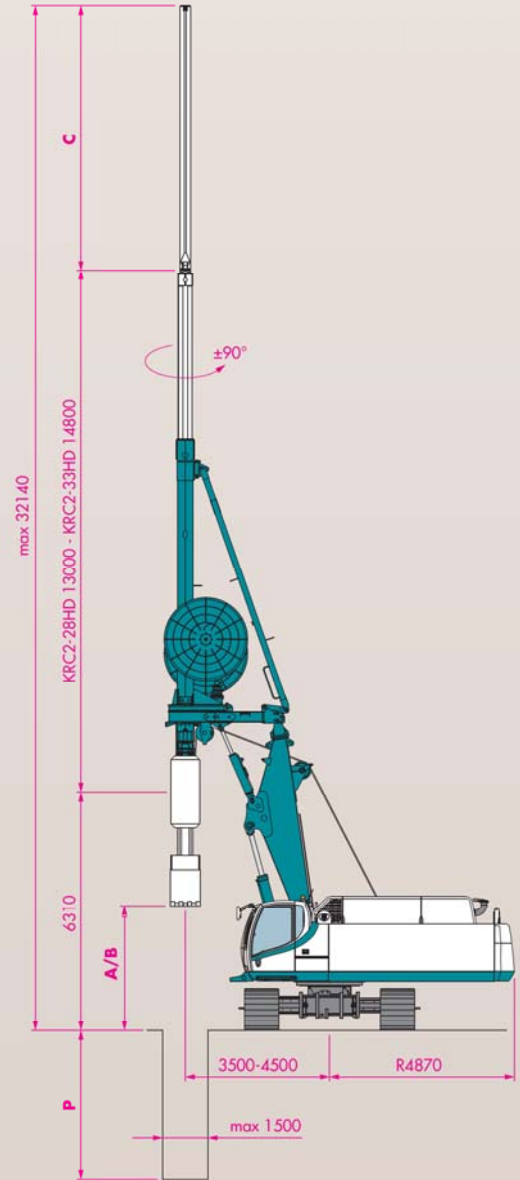

## TRANSPORT DIMENSIONS

DIMENSIONI DI TRASPORTO

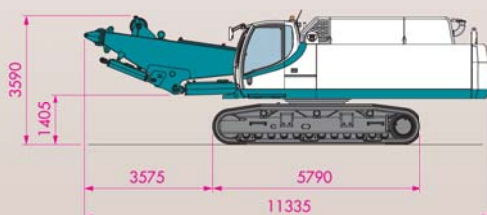

Weight / Peso ~ 63 t

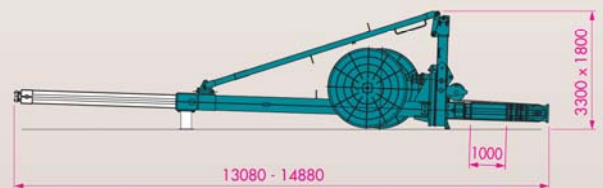

Weight / Peso ~ 14,3/15,4 t

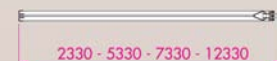

Weight / Peso ~ 300/600/770/1250 kg



# KRC 2 HD on B360xp

KRC 2 HD su B360XP

HYDRAULIC GRAB BENNA IDRAULICA		K2200HD	K2500HD	K3000HD
<b>A</b>	Height with closed jaws Altezza da terra a valve chiuse	3280	3030	2360
	Spacer 1000 Distanziale 1000			
<b>B</b>	Height with closed jaws Altezza da terra a valve chiuse	2280	2030	1360

<b>KRC 2-28 HD</b>	<b>C</b>	<b>P</b>	<b>P</b>	<b>P</b>
	Extension / Prolunga	(m)	(m)	(m)
	—	27,8	28	28,6
	2000	29,8	30	30,6
	5000	32,8	33	33,6
	7000	34,8	35	35,6
	12000	39,8	40	40,6

Weight of kelly bars / Peso aste ~7100 kg

<b>KRC 2-33 HD</b>	<b>C</b>	<b>P</b>	<b>P</b>	<b>P</b>
	Extension / Prolunga	(m)	(m)	(m)
	—	33,3	33,5	34
	2000	35,3	35,5	36
	5000	38,3	38,5	39
	7000	40,3	40,5	41
	12000	45,3	45,5	46

Weight of kelly bars / Peso aste ~8200 kg

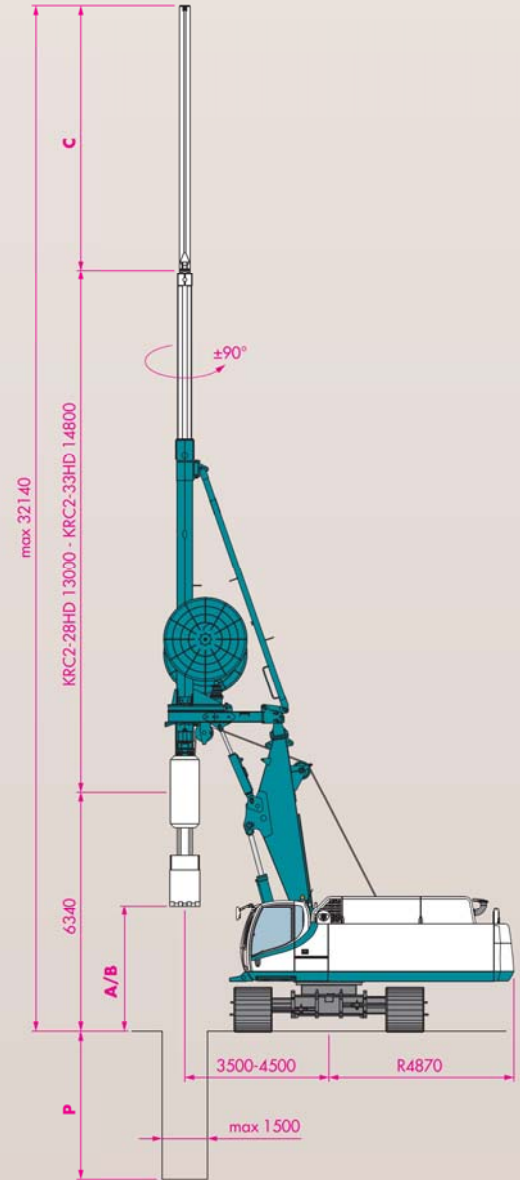

## TRANSPORT DIMENSIONS

DIMENSIONI DI TRASPORTO

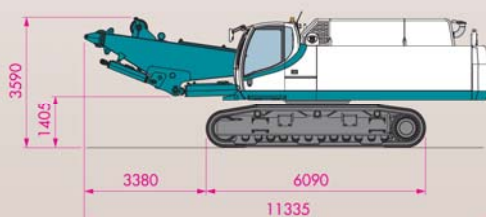

Weight / Peso ~ 76 t

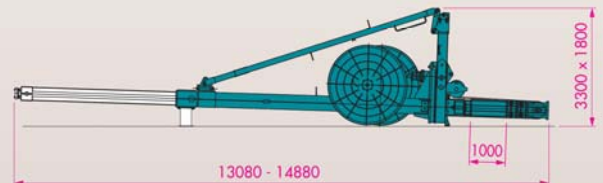

Weight / Peso ~ 14,3/15,4 t

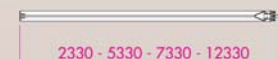

Weight / Peso ~ 300/600/770/1250 kg

# HYDRAULIC GRAB

## BENNA IDRAULICA

Jaw opening Apertura valve	mm	<b>A</b>	<b>2200</b>	<b>2500</b>	<b>3000</b>
Height with open jaws Altezza valve aperte	mm	<b>B</b>	3000	3100	3500
Height with closed jaws Altezza valve chiuse	mm	<b>C</b>	3600	3800	4300
Width of guide Larghezza carenature	mm	<b>D</b>	2000	2300	2750

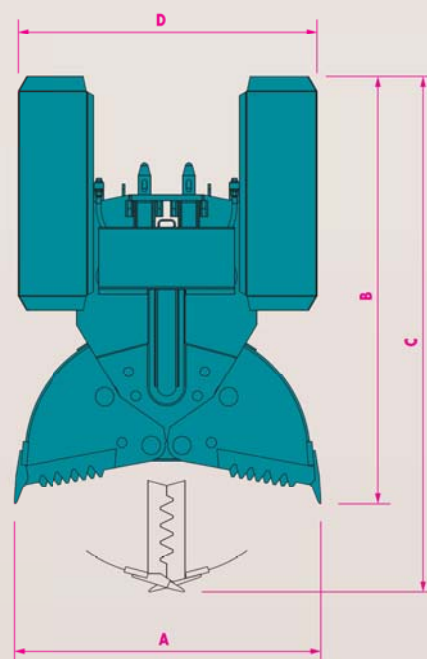

### K 2200

Jaw width	Larghezza valve	mm	<b>400 *</b>	<b>500</b>	<b>600</b>	<b>700</b>	<b>800</b>	<b>900</b>	<b>1000</b>	<b>1100</b>	<b>1200</b>
Jaw weight	Peso valve	Kg	690	750	830	1050	1130	1170	1380	1480	1600
Capacity	Capacità	lt	400	500	600	700	800	900	1000	1100	1200
Grab weight	Peso benna	Kg	2690	2750	2880	3150	3250	3350	3500	3650	3800
Closing force	Spinta chiusura	t	120	120	120	120	120	120	120	120	120

### K 2500

Jaw width	Larghezza valve	mm	<b>400 *</b>	<b>500</b>	<b>600</b>	<b>700</b>	<b>800</b>	<b>900</b>	<b>1000</b>	<b>1100</b>	<b>1200</b>
Jaw weight	Peso valve	Kg	850	930	1040	1170	1300	1450	1620	1800	1950
Capacity	Capacità	lt	440	540	680	800	940	1000	1200	1300	1440
Grab weight	Peso benna	Kg	3100	3350	3500	3670	3850	4050	4250	4500	4700
Closing force	Spinta chiusura	t	120	120	120	120	120	120	120	120	120

### K 3000

Jaw width	Larghezza valve	mm	<b>400 *</b>	<b>500</b>	<b>600</b>	<b>700</b>	<b>800</b>	<b>900</b>	<b>1000</b>	<b>1100</b>	<b>1200</b>
Jaw weight	Peso valve	Kg	1150	1300	1500	1700	1900	2150	2350	2550	2800
Capacity	Capacità	lt	800	975	1200	1380	1580	1780	1975	2170	2370
Grab weight	Peso benna	Kg	4100	4550	4820	5060	5300	5600	5800	6030	6300
Closing force	Spinta chiusura	t	120	120	120	120	120	120	120	120	120

### K 2500 HD

Jaw width	Larghezza valve	mm		<b>600</b>	<b>700</b>	<b>800</b>	<b>900</b>	<b>1000</b>	<b>1100</b>	<b>1200</b>	<b>1500</b>
Jaw weight	Peso valve	Kg		1250	1400	1560	1750	1950	2160	2340	2800
Capacity	Capacità	lt		680	800	940	1000	1200	1300	1440	1800
Grab weight	Peso benna	Kg		4200	4400	4600	4800	5100	5400	5600	6000
Closing force	Spinta chiusura	t		180	180	180	180	180	180	180	180

### K 3000 HD

Jaw width	Larghezza valve	mm			<b>800</b>	<b>900</b>	<b>1000</b>	<b>1100</b>	<b>1200</b>	<b>1500</b>
Jaw weight	Peso valve	Kg			2700	3000	3200	3450	3700	4300
Capacity	Capacità	lt			1580	1780	1975	2170	2370	2950
Grab weight	Peso benna	Kg			7500	7800	8000	8250	8500	9200
Closing force	Spinta chiusura	t			180	180	180	180	180	180

\* With special kelly bars / Con arte speciali

Other dimensions on request / Disponibili su richiesta altre dimensioni



casagrande **B300** XP vipp

# DIAPHRAGM WALL EQUIPMENT



KRC 1 on B125XP



KRC 1 on B175XP



KRC 2 on B200XP



KRC 2 HD on B250XP



KRC 2 HD on B300XP



KRC 2 HD on B360XP

All data contained in this brochure are indicative and does not take power losses into account. All data can be changed without notice.  
Tutti i dati riportati su questo catalogo sono indicativi e non considerano perdite di carico. Tali dati possono variare senza preavviso.



**casagrande**

CASAGRANDE S.P.A.

Via A. Malignani, 1 • IT 33074 Fontanafredda • Pordenone • Italy  
Tel. (+39) 0434 9941 • Fax (+39) 0434 997009  
www.casagrandegroup.com • info@casagrandegroup.com

**casagrande**  
group

