



casagrande

B125 XP

XP

B 125

HYDRAULIC PILING RIG

ATTREZZATURA IDRAULICA PER PALI



TECHNICAL SPECIFICATIONS

DATI TECNICI

B 125
HYDRAULIC PILING RIG

XP

PILING	PALI	
Max depth	Profondità max	50 m
Max diameter with casing - Crowd ram	Diametro max con tubo - Martinetto pull-down	1500 mm
Max diameter with casing oscillator	Diametro max con morsa giracolonna	1000 mm
C.F.A. CONTINUOUS FLIGHT AUGER	ELICA CONTINUA C.F.A.	
Max depth	Profondità max	23 m
Max diameter	Diametro max	800 mm
SOIL MIXING	SOIL MIXING	
Max depth	Profondità max	21 m
Max diameter	Diametro max	1000 mm
DIAPHRAGM WALL	DIAFRAMMI	
Max depth	Profondità max	30 m
Max length of trench	Lunghezza max scavo	2500 mm
Max width of trench	Larghezza max scavo	800 mm
UNDERCARRIAGE	CARATTERISTICHE CARRO	
Width with retracted/extended tracks	Larghezza con cingoli chiusi/ aperti	2500/3700 mm
Tracks length	Lunghezza cingoli	4510 mm
Shoes width	Larghezza pattini	600 mm
ENGINE	MOTORE	CUMMINS QSB 6.7 Aftercooler
Engine conforms to Exhaust Emission Standard	Motore conforme agli standard di emissione	EU Stage IIIA/IV - US EPA TIER III/IVf
Power at 2200 rpm	Potenza a 2200 giri	164/168 kW
Hydraulic power	Potenza idraulica	140 kW
MAIN WINCH	ARGANO PRINCIPALE	
Nominal line pull on 1 st layer	Tiro nominale 1° strato	160 kN
Max line speed	Velocità max fune	72 m/min
AUXILIARY WINCH	ARGANO AUSILIARIO	
Nominal line pull on 1 st layer	Tiro nominale 1° strato	70 kN
Max line speed	Velocità max fune	63 m/min
MAIN WINCH FOR KRC USE	ARGANO PRINCIPALE USO KRC	
Nominal line pull on 1 st layer	Tiro nominale 1° strato	135 kN
Max line speed	Velocità max fune	93 m/min
ROTARY HEAD	TESTA ROTARY	H12 SX * H12
Max torque	Coppia max	112 kNm 125 kNm
Max drilling speed	Velocità max lavoro	70 rpm 33 rpm
Discharge speed	Velocità di scarico	— 120 rpm
CROWD RAM	MARTINETTO PULL-DOWN	
Max line pull	Tiro max	190 kN
Max crowd	Spinta max	130 kN
Stroke	Corsa	3800 mm
MAST INCLINATION	INCLINAZIONE MAST	
Forward Backward Lateral	Avanti Indietro Laterale	3° 15° ±3°
WEIGHT	PESO	
Weight in working condition	Attrezzatura in condizioni di lavoro	~ 41 t

* For Soil Mixing application / Per impiego Soil Mixing

PILING ARRANGEMENT - PDC

ALLESTIMENTO PALI - PDC

CROWD RAM - MARTINETTO PULL-DOWN

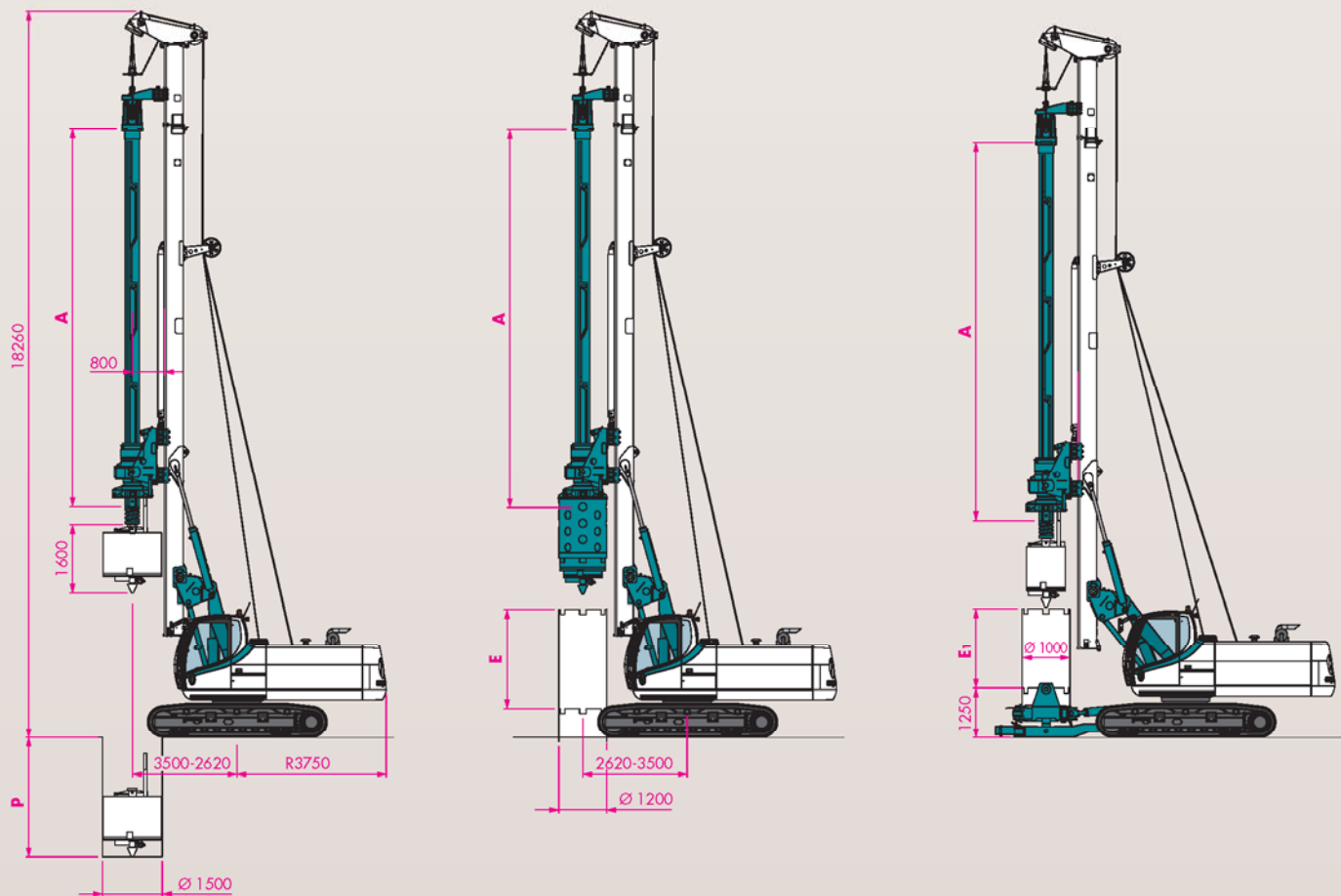

DRILLING DEPTH		PROFONDITÀ DI SCAVO				
Nominal kelly bars length	Larghezza nominale aste		A	7500	9500	11000
Kelly bars 4 element	Aste a 4 elementi	m	P	26	34	40
Kelly bars 5 element	Aste a 5 elementi	m	P	32	42	50
Casing length	Lunghezza tubo	mm	E	2500	2500	—
Casing length with oscillator	Lunghezza tubo con morsa	mm	E₁	2000	2000	—

TRANSPORT DIMENSIONS

DIMENSIONI DI TRASPORTO

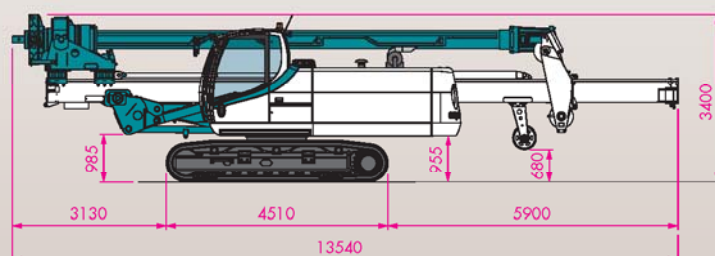

WEIGHT · PESO

~ 41 t

with kelly bars · con aste 9500

C.F.A. ARRANGEMENT

ALLESTIMENTO C.F.A.

B 125
HYDRAULIC PILING RIG

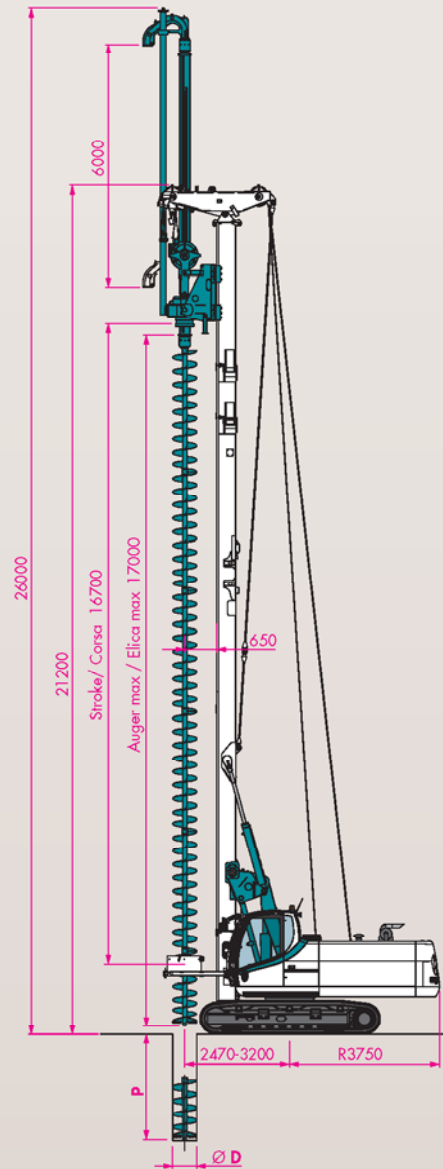

DRILLING DEPTH	PROFONDITÀ DI SCAVO		CFA
Max Diameter	Diametro max	Ø	D 800
Max depth with rotating auger cleaner	Profondità max con pulisci elica rotante	m	P 21,6
Max depth with star auger cleaner	Profondità max con pulisci elica stellare	m	P 22,7
Extraction force	Forza di estrazione	kN	450
Extraction / crowd force	Forza di estrazione / spinta	kN	—

TRANSPORT DIMENSIONS

DIMENSIONI DI TRASPORTO

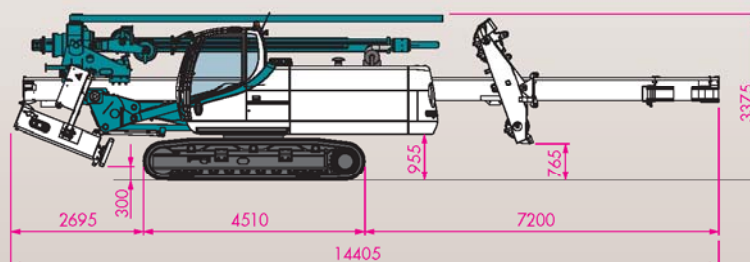

WEIGHT • PESO

~ 38 t



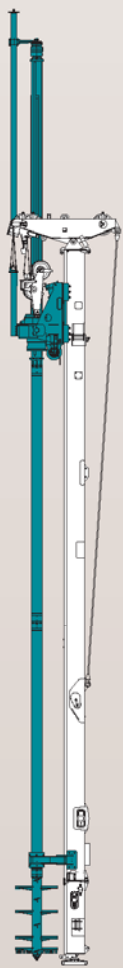

SOIL MIXING
Depth 21 m
Ø 1000 mm

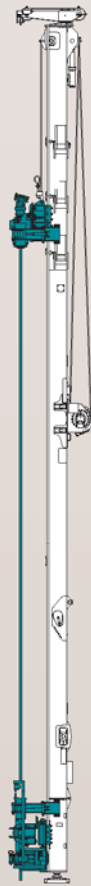

MICROPILING
Stroke 16 m
Ø 90 ÷ 406 mm

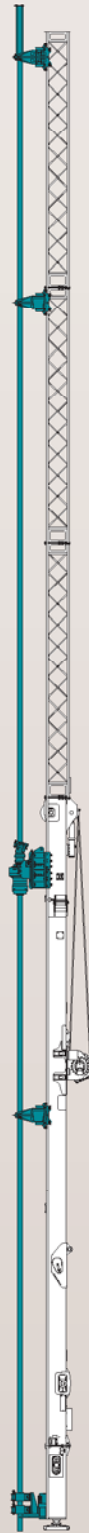

JET GROUTING
Depth 68 m
with rod loader
Ø 90 ÷ 406 mm

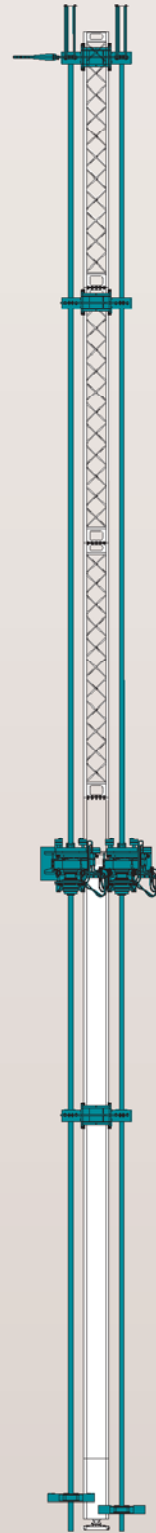

BI-JET GROUTING
Depth 32 m
Ø 40 ÷ 254 mm

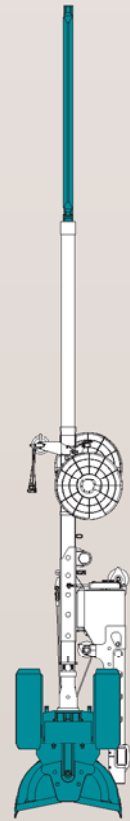

**KRC
DIAPHRAGM WALL**
Depth 30 m
Trench 800 x 2500 mm

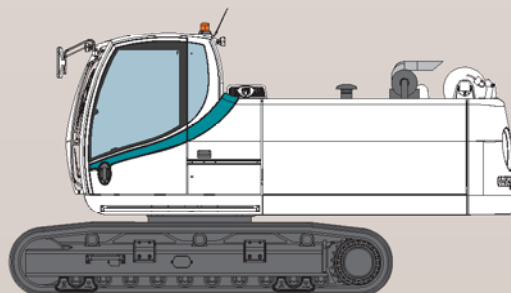

CASAGRANDE HYDRAULIC PILING RIGS RANGE



B125XP



B175XP



B200XP

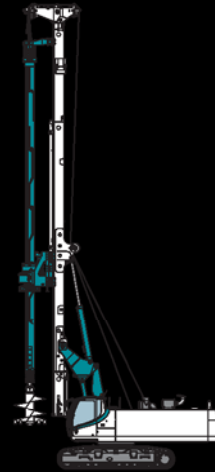

B250XP



B300XP

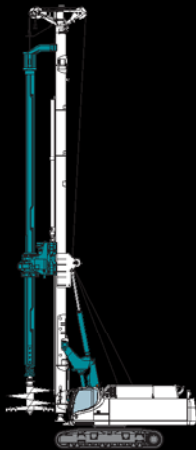

B360XP

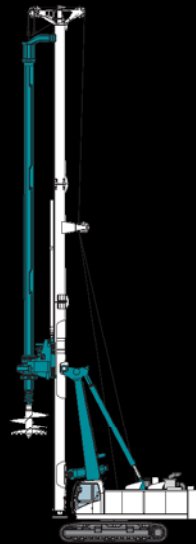

C850

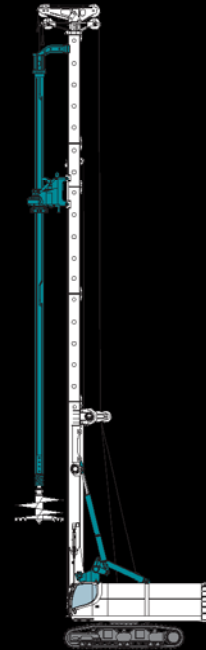

B450XP

All data contained in this brochure are indicative and does not take power losses into account. All data can be changed without notice.
Tutti i dati riportati su questo catalogo sono indicativi e non considerano perdite di carico. Tali dati possono variare senza preavviso.



casagrande

CASAGRANDE S.P.A.
Via A. Malignani, 1 • IT 33074 Fontanafredda • Pordenone • Italy
Tel. (+39) 0434 9941 • Fax (+39) 0434 997009
www.casagrandegroup.com • Info@casagrandegroup.com

